

CADET BOY'S TEAMS

ENTERED 42 TEAMS

1st STAGE

LEVEL 1

Group A		1	2	3	4		
1	GER						
2	HRV						
3	DEN						
4	LAT						
		16/07	09.00	T1	A 1-4		
		16/07	09.00	T2	A 2-3		
		16/07	16.30	T10	A 1-3		
		16/07	16.30	T11	A 2-4		
		17/07	11.30	T1	A 1-2		
		17/07	11.30	T2	A 3-4		

Group B		1	2	3	4		
1	UKR						
2	SCG						
3	ROU						
4	ENG						
		16/07	09.00	T3	B 1-4		
		16/07	09.00	T4	B 2-3		
		16/07	16.30	T12	B 1-3		
		16/07	16.30	T13	B 2-4		
		17/07	11.30	T3	B 1-2		
		17/07	11.30	T4	B 3-4		

Group C		1	2	3	4		
1	RUS						
2	TUR						
3	HUN						
4	SVK						
		16/07	09.00	T5	C 1-4		
		16/07	09.00	T6	C 2-3		
		16/07	16.30	T14	C 1-3		
		16/07	16.30	T15	C 2-4		
		17/07	11.30	T5	C 1-2		
		17/07	11.30	T6	C 3-4		

Group D		1	2	3	4		
1	CZE						
2	POR						
3	FRA						
4	SWE						
		16/07	09.00	T7	D 1-4		
		16/07	09.00	T8	D 2-3		
		16/07	16.30	T16	D 1-3		
		16/07	16.30	T17	D 2-4		
		17/07	11.30	T7	D 1-2		
		17/07	11.30	T8	D 3-4		

LEVEL 2

Group E		1	2	3	4	5	
1	BLR						
2	ESP						
3	SVN						
4	IRL						
5	KOS						
		16/07	09.00	T18	E 1-5		
		16/07	09.00	T19	E 2-4		
		16/07	14.00	T14	E 1-4		
		16/07	14.00	T15	E 2-3		
		16/07	19.00	T18	E 2-5		
		16/07	19.00	T19	E 3-4		
		17/07	11.30	T18	E 1-3		
		17/07	11.30	T19	E 4-5		
		17/07	16.30	T1	E 1-2		
		17/07	16.30	T2	E 3-5		

Group F		1	2	3	4	5	
1	BUL						
2	SUI						
3	BIH						
4	MTN						
5	0						
		16/07	09.00	T21	F 2-4		
		16/07	14.00	T16	F 1-4		
		16/07	14.00	T17	F 2-3		
		16/07	19.00	T21	F 3-4		
		17/07	11.30	T20	F 1-3		
		17/07	16.30	T3	F 1-2		

Group G		1	2	3	4		
1	LUX						
2	LTU						
3	ISL						
4	EST						
		16/07	09.00	T22	G 1-4		
		16/07	09.00	T23	G 2-3		
		16/07	19.00	T22	G 1-3		
		16/07	19.00	T23	G 2-4		
		17/07	16.30	T5	G 1-2		
		17/07	16.30	T6	G 3-4		

Group H		1	2	3	4		
1	ITA						
2	NED						
3	FIN						
4	WAL						
		16/07	09.00	T24	H 1-4		
		16/07	09.00	T25	H 2-3		
		16/07	19.00	T24	H 1-3		
		16/07	19.00	T25	H 2-4		
		17/07	16.30	T7	H 1-2		
		17/07	16.30	T8	H 3-4		

Group I		1	2	3	4		
1	BEL						
2	GRE						
3	CYP						
4	MDA						
		16/07	09.00	T26	I 1-4		
		16/07	09.00	T27	I 2-3		
		16/07	19.00	T26	I 1-3		
		16/07	19.00	T27	I 2-4		
		17/07	16.30	T10	I 1-2		
		17/07	16.30	T11	I 3-4		

Group J		1	2	3	4		
1	POL						
2	AUT						
3	NOR						
4	SCO						
		16/07	09.00	T28	J 1-4		
		16/07	09.00	T29	J 2-3		
		16/07	19.00	T28	J 1-3		
		16/07	19.00	T29	J 2-4		
		17/07	16.30	T12	J 1-2		
		17/07	16.30	T13	J 3-4		

Play-off matches Nr.1

4 teams finished 3rd in groups A, B, C, D (A--D(3))

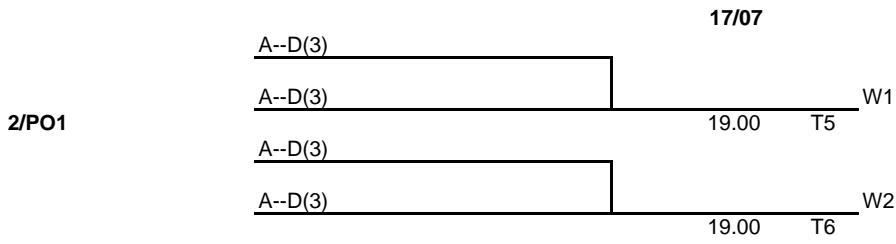

Play-off matches Nr.2

2 losers of play-off matches Nr.1 (L1, L2)

4 teams finished 4th in groups A, B, C, D (A--D(4))

6 winners of the groups E, F, G, H, I, J (E--J(1))

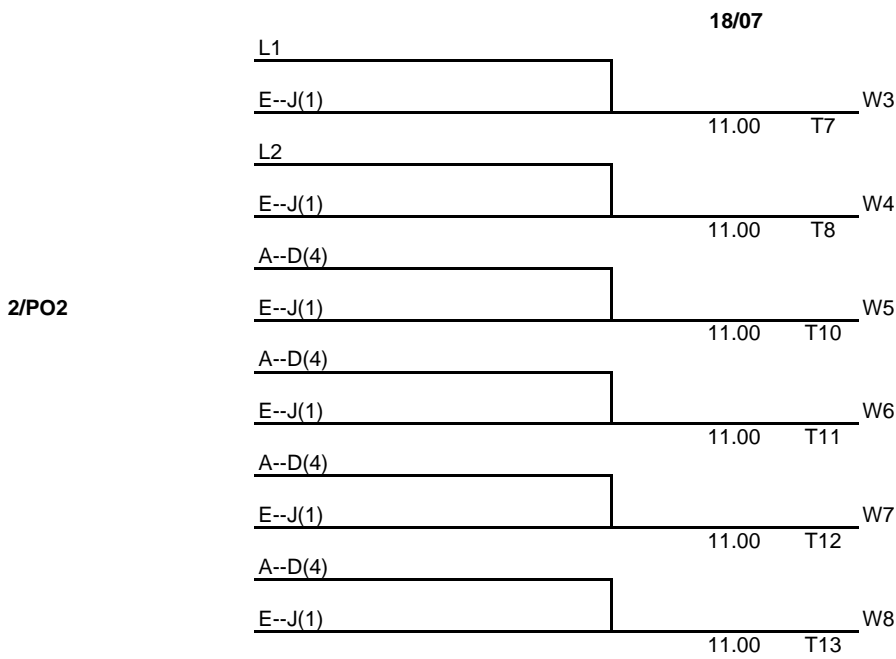

CADET BOY'S TEAMS

3rd STAGE

LEVEL 1

Final places 1-16

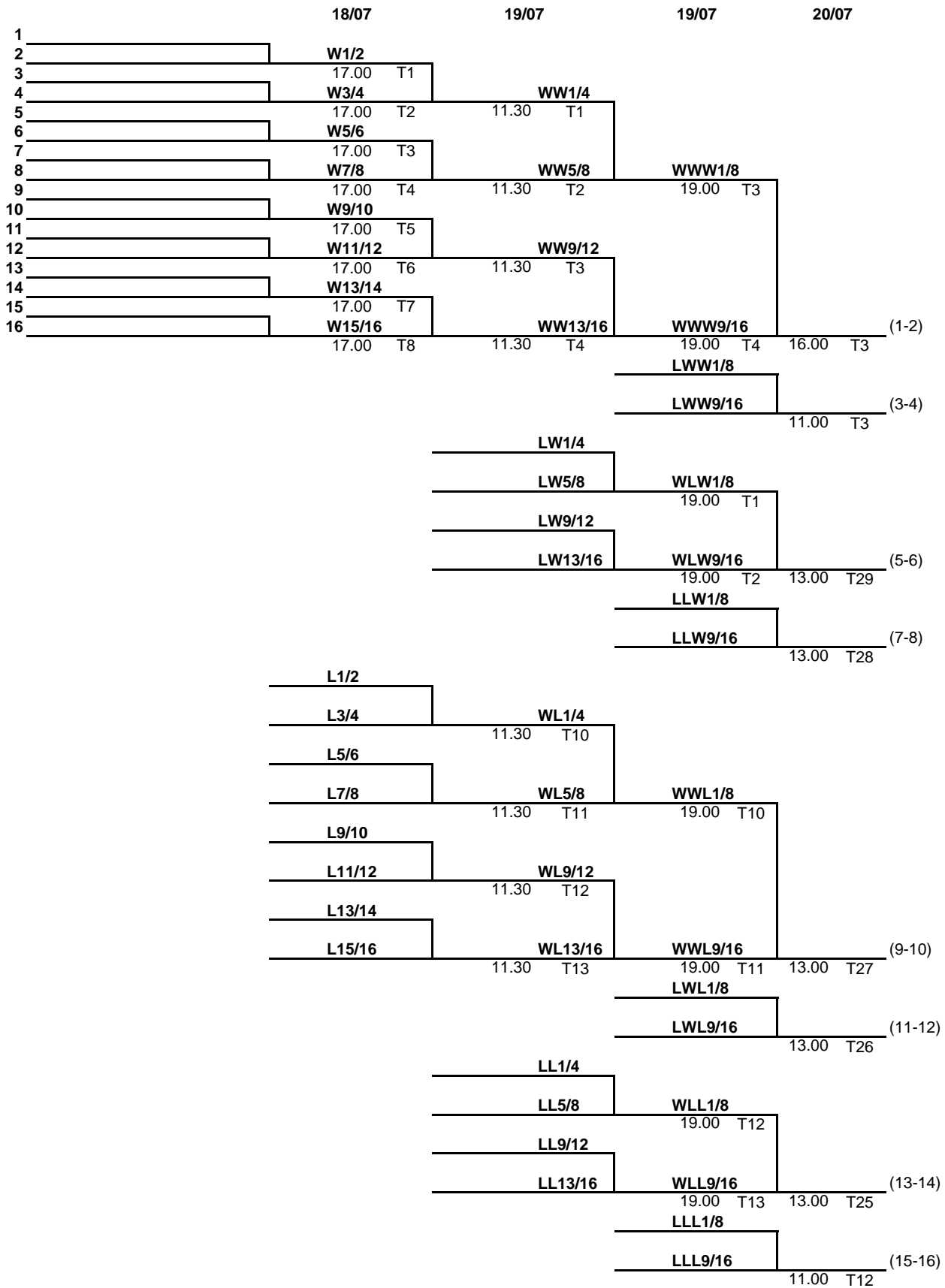

CADET BOY'S TEAMS

3rd STAGE

LEVEL 2

Final places 17-28

Entered 12 teams:

6 losers of play-off matches Nr 2

6 teams finished 2nd in groups E, F, G, H, I, J

Group K	1	2	3		
1					
2					
3					
	18/07	17.00	T18	K 2-3	
	19/07	09.00	T18	K1-3	
	19/07	14.00	T19	K1-2	

Group L	1	2	3		
1					
2					
3					
	18/07	17.00	T19	L 2-3	
	19/07	09.00	T19	L1-3	
	19/07	14.00	T20	L1-2	

Group M	1	2	3		
1					
2					
3					
	18/07	17.00	T20	M 2-3	
	19/07	09.00	T20	M1-3	
	19/07	14.00	T21	M1-2	

Group N	1	2	3		
1					
2					
3					
	18/07	17.00	T21	N 2-3	
	19/07	09.00	T21	N1-3	
	19/07	14.00	T22	N1-2	

19/07

20/07

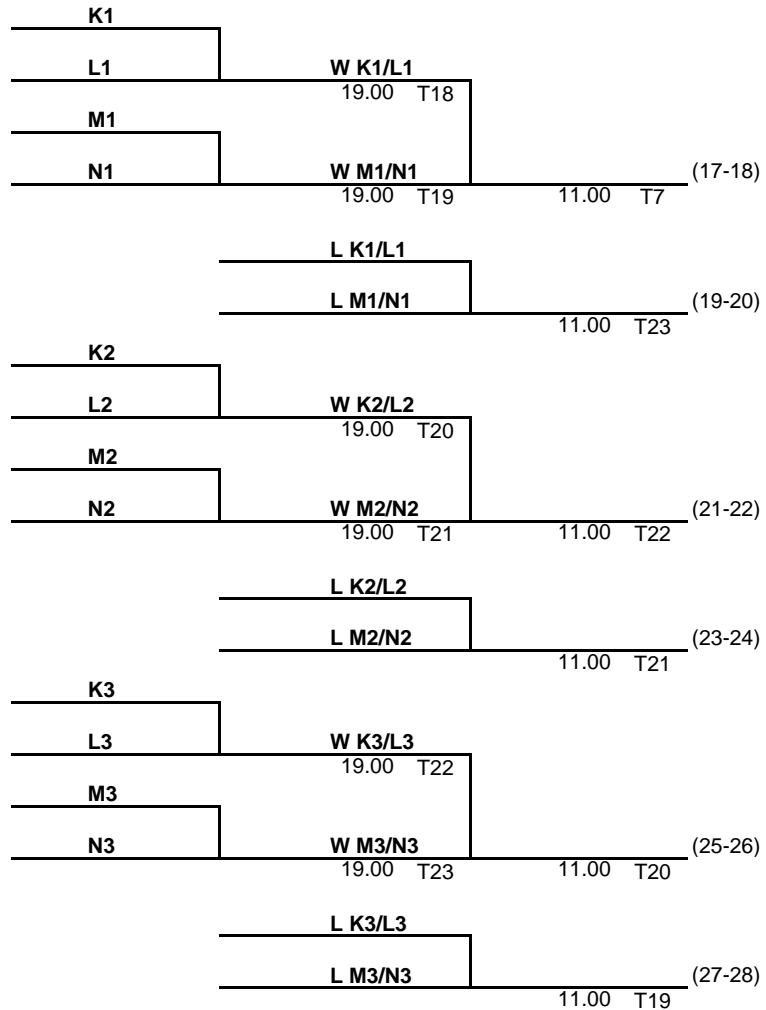

CADET BOY'S TEAMS

3rd STAGE

LEVEL 3

Final places 29-42

Entered 14 teams:

6 teams finished 3rd in groups E, F, G, H, I, J

6 teams finished 4th in groups E, F, G, H, I, J

2 teams finished 5th in groups E, F

Group O	1	2	3	4		
1						
2						
3						
4						
	18/07	09.00	T21	O 1-4		
	18/07	09.00	T22	O 2-3		
	18/07	13.00	T8	O 1-3		
	18/07	13.00	T10	O 2-4		
	18/07	19.00	T17	O 1-2		
	18/07	19.00	T18	O 3-4		

Group P	1	2	3	4		
1						
2						
3						
4						
	18/07	09.00	T23	P 1-4		
	18/07	09.00	T24	P 2-3		
	18/07	13.00	T11	P 1-3		
	18/07	13.00	T12	P 2-4		
	18/07	19.00	T19	P 1-2		
	18/07	19.00	T20	P 3-4		

Group Q	1	2	3		
1					
2					
3					
	18/07	09.00	T25	Q 2-3	
	18/07	13.00	T13	Q1-3	
	18/07	19.00	T21	Q1-2	

Group R	1	2	3		
1					
2					
3					
	18/07	09.00	T26	R 2-3	
	18/07	13.00	T14	R1-3	
	18/07	19.00	T22	R1-2	

19/07

20/07

